

AS-3001 Wiring Schematic

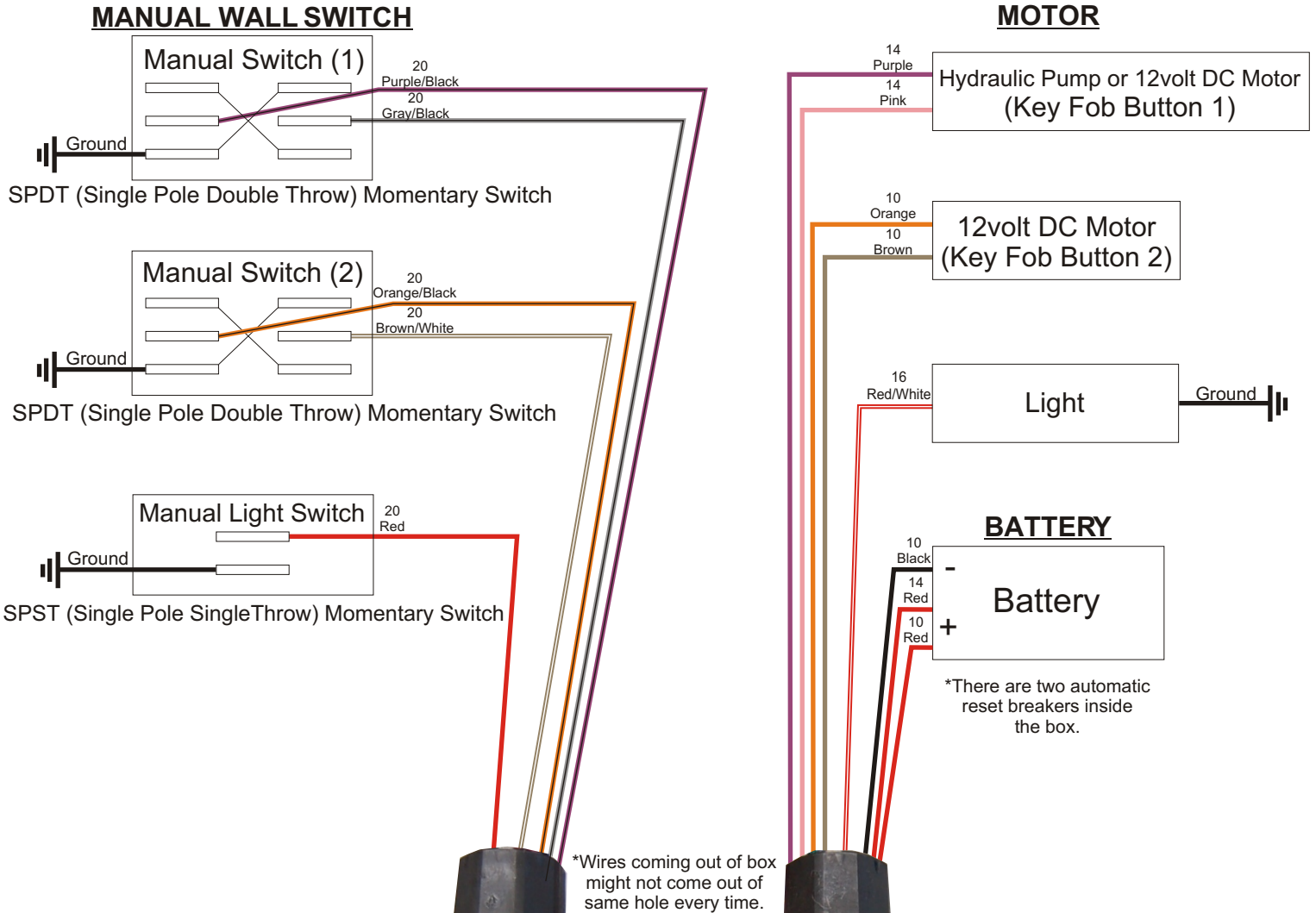

- Depress both Buttons to operate a Light

AS-3001
ON/OFF Switch Above

WIRE FUNCTIONS BY COLOR:

10 Gauge Red - 30A Battery Power* 10 Gauge Black - Main Ground 10 Gauge Orange - Motor #2 Extend 10 Gauge Brown - Motor #2 Retract 14 Gauge Red - 15A Battery Power* 14 Gauge Purple - Motor #1 Extend 14 Gauge Pink - Motor #1 Retract 16 Gauge Red/White - Extra Light	20 Gauge Org/Blk - Motor #2 SPDT Mom. Sw. 20 Gauge Brn/Wht - Motor #2 SPDT Mom. Sw. 20 Gauge Brown - Motor #2 SPST Mom. Sw. 20 Gauge Pur/Blk - Motor #1 SPDT Mom. Sw. 20 Gauge Gry/Blk - Motor #1 SPDT Mom. Sw. 20 Gauge Pink - Motor #1 SPST Mom. Sw. 20 Gauge Red - Extra Light SPST Mom. Sw. 20 Gauge Red/Black - Ignition Sense
---	--

* - Circuit Breakers Located Inside

KEY FOB OPERATION:

Button 1 - 12volt Elec. Motor #1 (Ext / Ret)
 Button 2 - 12volt Elec. Motor #2 (Ext / Ret)
 Buttons 1 & 2 - Extra Light (On / Off)

* NOTE - ALL SWITCH INPUTS MUST BE GROUNDS!

Alta Resources LLC (888) 421-5874 www.altaresourcesllc.com *Patent# 6,900,603*

The following 3 wires are not used:

20 Gauge
Brown
Pink
Red/Black

* All exterior wall switches must be water proof with sealant on the back terminals for protection.